

MAGNETIC SNUBBER FOR 200W PFC WITH UNIVERSAL MAINS

by C. Adragna and N. Tricomi

In high voltage continuous mode boost converters, a significant part of the power mosfet switching losses is related to the turn-on edge.

In fact, at turn on, the power mosfet has to sustain both the boost diode reverse recovery and the stray capacitances associated energies.

Moreover, the additional peak current due to the recovery of the diode can be significantly high, in particular at high temperature, thus increasing the high frequency noise, the E.M.I. filter requirements and reducing efficiency.

The turn on peak current, generating all the above mentioned problems, has been dramatically reduced by using the magnetic snubber we propose at Fig. 1b.

The concept of this snubber is to reduce (and control) the turn-on di/dt of the mosfet to the most convenient value, considering the voltages and switching frequency applied to the system.

Design Guidelines

The di/dt value can be selected so to reduce current-voltage overlap at turn-on but the main issue is generating a low level of EMI emission. On the other hand, the transition of the current in the switch from its peak value (I_{pk}) to zero has to be a small portion of the switch ON-time.

A reasonable value is around 100A/μs, which leads to L_s = 4μH.

The inductance value (L_s) is selected so to have the desired di/dt. At MOSFET turn-on the voltage applied to the choke is V_{out} (until the boost diode has finished recovering):

$$L = \frac{V_{out}}{(di/dt)}$$

Figure 1a: Voltage Snubber.

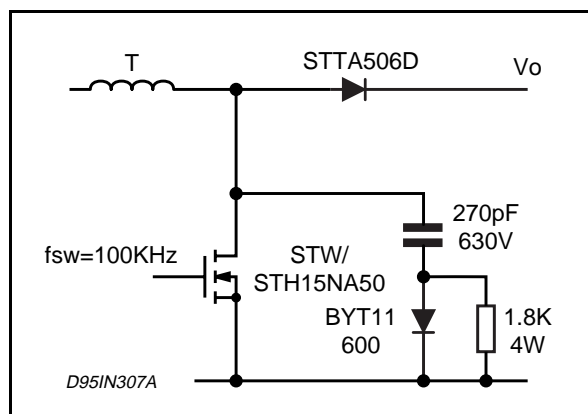

AN831/1297

The capacitor absorbs the energy stored in the choke and its voltage builds up from zero to a maximum (V_c) that can be found with energy balance considerations. This fixes the capacitance value. The resistor is selected so to have an RC constant much lower than the switch OFF-time. Part of the energy stored in the choke is dumped into the output but the majority is dissipated in the resistor so this must be properly rated.

The diode (a 1A device is OK for 200W P_{out}) need not be a ultra fast recovery one since it does not conduct at MOSFET turn-on. It must be, instead, a fast turn-on type since it undergoes a very steep current peak.

The RCD group clamps the extra voltage on the MOSFET's drain at turn-off, needed to reset the choke, so that the voltage rating of the MOSFET is not exceeded.

The values mentioned in the test circuit (Fig. 1b) are related to the application 200W/100kHz UNIVERSAL MAINS "EVAL4981A".

Figure 1a shows the voltage snubber circuit used in the same evaluation board (EVAL4981A).

The benefits of this magnetic snubber are reported in the following table:

V _{in}	with voltage snubber		with current snubber		P _{out}
	Pin	η	Pin	η	
85	232	88.4	222	92.3	205
220	220	93.2	216	94.8	205
270	217	94.4	213	96.2	205

Analysing the table of results, it is possible to appreciate lower power dissipation.

Figure 1b: Magnetic Snubber.

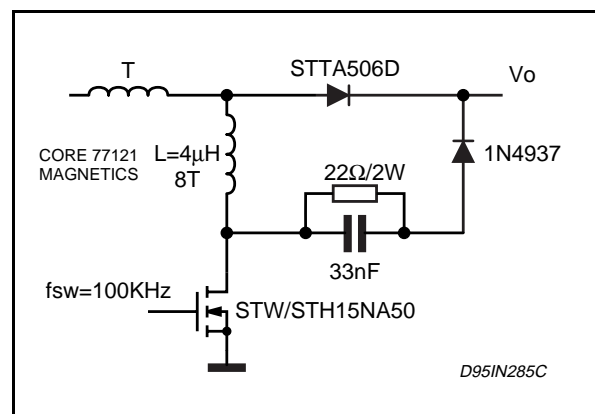

1/3

APPLICATION NOTE

This additional benefit, at 85Vac input mains, corresponds to about 10W, where the most of this reduced power dissipation is located in the power mos.

There are three main benefits: reduction of current-voltage overlap at switch turn-on (which reduces switching losses in the MOSFET), reduction of the

reverse peak current in the diode (which means less power dissipation both in the diode and in the MOSFET: the latter "can't see" the recovery of the diode since it is isolated by the choke) and, last but not least, the controlled di/dt leads to less EMI.

Information furnished is believed to be accurate and reliable. However, SGS-THOMSON Microelectronics assumes no responsibility for the consequences of use of such information nor for any infringement of patents or other rights of third parties which may result from its use. No license is granted by implication or otherwise under any patent or patent rights of SGS-THOMSON Microelectronics. Specification mentioned in this publication are subject to change without notice. This publication supersedes and replaces all information previously supplied. SGS-THOMSON Microelectronics products are not authorized for use as critical components in life support devices or systems without express written approval of SGS-THOMSON Microelectronics.

© 1997 SGS-THOMSON Microelectronics – Printed in Italy – All Rights Reserved

SGS-THOMSON Microelectronics GROUP OF COMPANIES

Australia - Brazil - Canada - China - France - Germany - Italy - Japan - Korea - Malaysia - Malta - Morocco - The Netherlands -
Singapore - Spain - Sweden - Switzerland - Taiwan - Thailand - United Kingdom - U.S.A.